



**MANUAL DE MONTAGEM
ASSEMBLY INSTRUCTIONS
INSTRUCCIONES DE MONTAJE**

COD BR: BC 93

Sumário Summary Resumen

Introdução Introduction Introducción	3
Antes de começar Before starting Antes de comenzar	4
Evite acidentes Avoid accidents Evitar accidentes	4
Dimensões e ferramentas Dimensions and tools Dimensiones y herramientas	5
Identificação das peças Identifying parts Identificación de las piezas	6
Acessórios incluídos na caixa Hardware included in box Accesorios incluidos en la caja	7
Montagem do móvel Furniture assembly Montaje del mueble	8

Introdução Introduction Introducción

Leia atentamente este manual e siga os passos indicados para que o produto não perca a garantia e também para uma perfeita montagem.

For the perfect fit, please read this manual carefully and follow indicated steps.

Lea este manual y siga los pasos para que el producto no pierda la garantía y también para el ajuste perfecto.

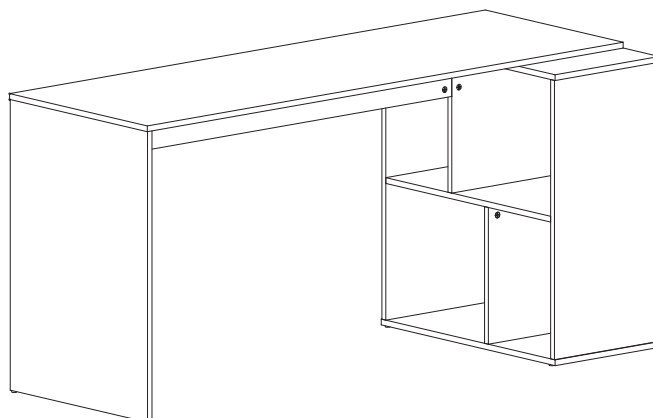

Antes de começar Before starting Antes de comenzar

Antes de começar a montagem prepare o ambiente, deixando-o completamente limpo e com bom espaço para iniciar o trabalho.

Prepare the room before starting the assembly, leaving it completely clean and the area in good condition to start the work.

Antes de comenzar el montaje preparar el ambiente, dejándolo completamente limpio y con bueno espacio para comenzar el trabajo.

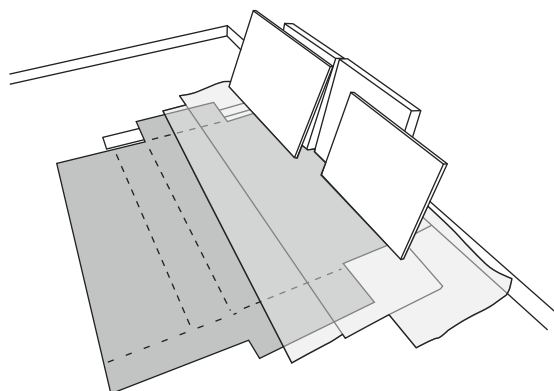

Utilize o papelão da própria embalagem para separar e apoiar as peças retiradas das caixas.

Use the cardboard of the packaging to separate and support the parts removed from the boxes.

Utilice el cartón de la embalaje para separar y apoyar las piezas desmontadas de las cajas.

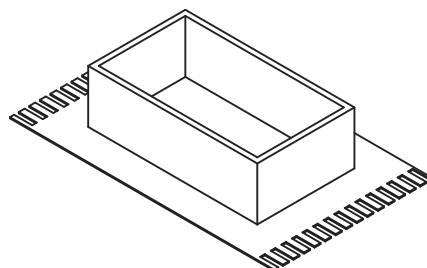

Forre a área de montagem com um cobertor ou tapete. Assim, você evita avarias nas peças durante o processo de montagem.

Cover the assembly area with a blanket or carpet to avoid damaging the parts during the assembly process.

Cubrir la zona de ensamble con una manta o alfombra. De este modo, se evitan daños en las piezas durante el proceso de montaje.



Evite acidentes Avoid accidents Prevenir accidentes

Solicitamos observar atentamente as orientações de montagem como: fixação do produto na parede, colocação de cola em locais específicos necessários, o peso suportado pelo produto, etc...

You are requested to carefully observe the assembly instructions regarding: fixing of products to the wall, adding glue where indicated, product weight limit, etc.

Pedimos que lea atentamente las instrucciones, principalmente las informaciones de fijación del producto en la pared, colocación de pegamento en local específico y necesario, el peso soportado por el producto etc...

Não escale ou se apoie no móvel.

Do not climb or lean on the furniture.

No se suba ni se apoye en el mueble.

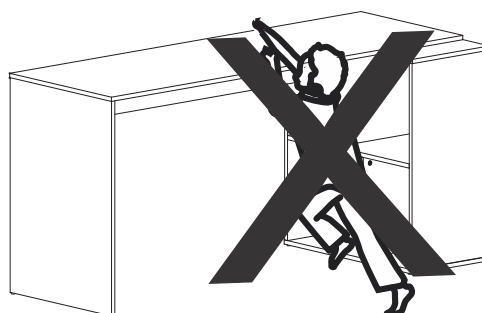

Dimensões e ferramentas
 Dimensions and tools
 Dimensiones y herramientas

Dimensões:
 L: 1600 A: 780 P: 675 mm
 Dimensions:
 W: 62.99 H: 30.70 D: 26.57 inches
 Dimensiones:
 L: 1600 A: 780 P: 675 mm

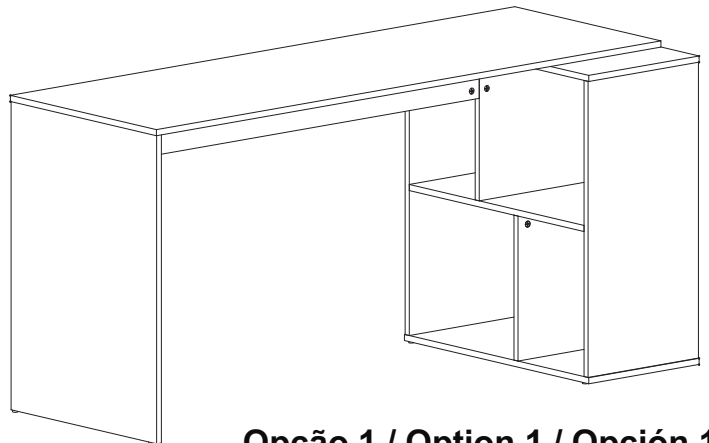

Opção 1 / Option 1 / Opción 1

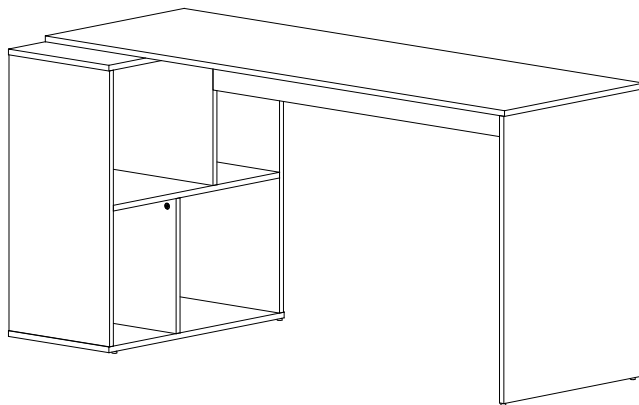

Opção 2 / Option 2 / Opción 2

Limpeza
 Cleaning
 Limpieza

Pano levemente umedecido com água, seguido de pano seco, não utilizar produtos químico ou abrasivos.
 You can clean the product with slightly dampened cloth followed by a dry cloth. Do not use chemicals or abrasives.
 Solamente utilizar un paño húmedo y después un paño seco, no utilice productos químicos o abrasivos.

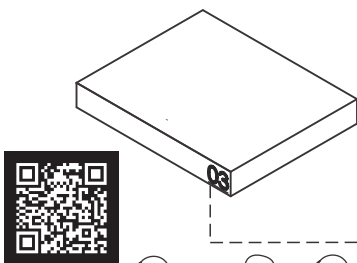

UTILIZE ALCOOL APENAS PARA REMOVER O NUMERO DAS PEÇAS
USE ALCOHOL ONLY TO REMOVE PART NUMBERS
UTILICE ALCOHOL SOLAMENTE PARA ELIMINAR EL NUMERO DE LAS PIEZAS

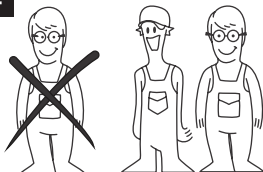

Para facilitar a montagem, utilize uma parafusadeira elétrica.
 To speed assembly, use an electronic screwdriver.
 Para facilitar el armado, utilice un destornillador eléctrico.

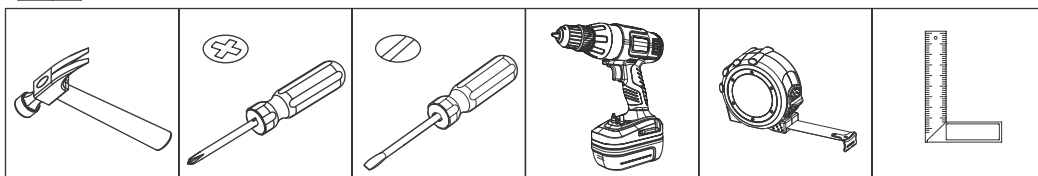

COD BR: BC 93

PEÇA	DESCRIÇÃO	QUANT.	PART DESCRIPTION	QTY	PIEZA DESCRIPCIÓN	CANTIDAD
001	BASE	1	001 BASE	1	001 BASE	1
002	TAMPO MENOR	1	002 LOWER TOP	1	002 TAPA MENOR	1
003	LATERAL MENOR	2	003 LOWER SIDE	2	003 LATERAL MENOR	2
004	PRATELEIRA	1	004 SHELF	1	004 REPISA	1
005	DIVISÓRIA INFERIOR	1	005 BOTTOM PARTITION	1	005 PARTICIÓN INFERIOR	1
006	DIVISÓRIA SUPERIOR	1	006 UPPER PARTITION	1	006 PARTICIÓN SUPERIOR	1
007	TAMPO MAIOR	1	007 LONGER TOP	1	007 TAPA MAIOR	1
008	LATERAL MAIOR	1	008 LONGER SIDE	1	008 LATERAL MAIOR	1
009	TRAVESSA	1	009 TRAVERSE	1	009 TRAVERSAÑO	1
010	COSTA	2	010 BACK	2	010 REVÉS	2

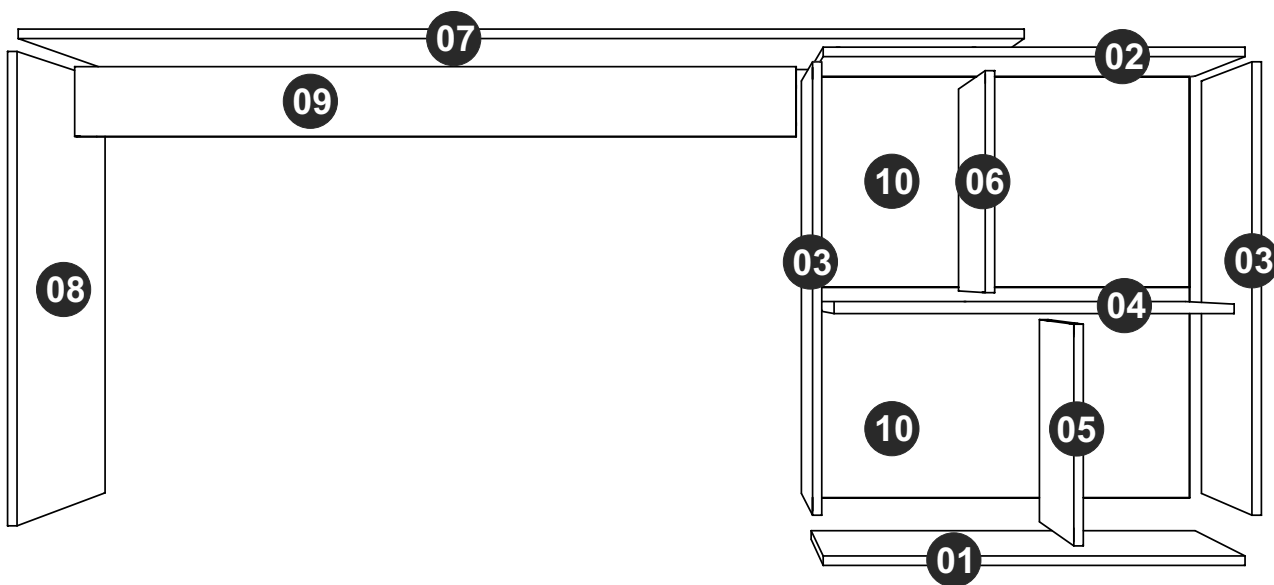



EF 000094 X 16



EF 000751 X 1



EF 000033 x 26
8x30



EF 000132 x 08
4X50 CC

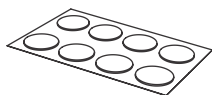

TAPA FUROS x 27
STICKER x 27
TAPAS PLÁSTICAS x 27



EF 000216 X 18

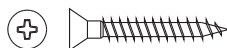

EF 000404 X 04
3,5X25 CC

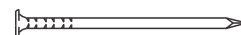

EF 000168 X 70
10X10 C/C



PÉS REDONDOS x 06
ROUND FEET x 06
PIES REDONDOS x 06



GIZ x 01
CHALK x 01
TIZA x 01

Utilize para medir as ferragens.

Utilice para medir el herraje.

Use for measuring the hardware.

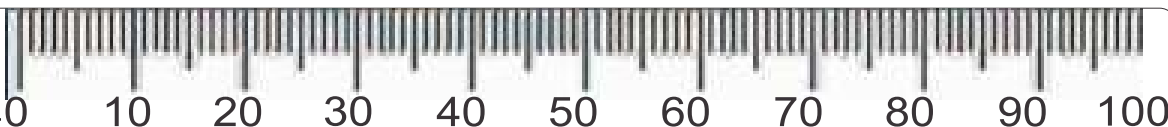

Garantia (exclusivo para o Brasil/exclusivo de Brasil/exclusive to Brazil):

A garantia dos produtos fabricados pela BRV Móveis, abrange eventuais defeitos-vícios de fabricação, no prazo estabelecido pelo código de Defesa do Consumidor, em seu artigo 26.II. o qual prevê a garantia de 90 (noventa) dias.

A = 34KG - 74.95 LB

B = 4KG - 8.81 LB

C = 3KG - 6.61 LB

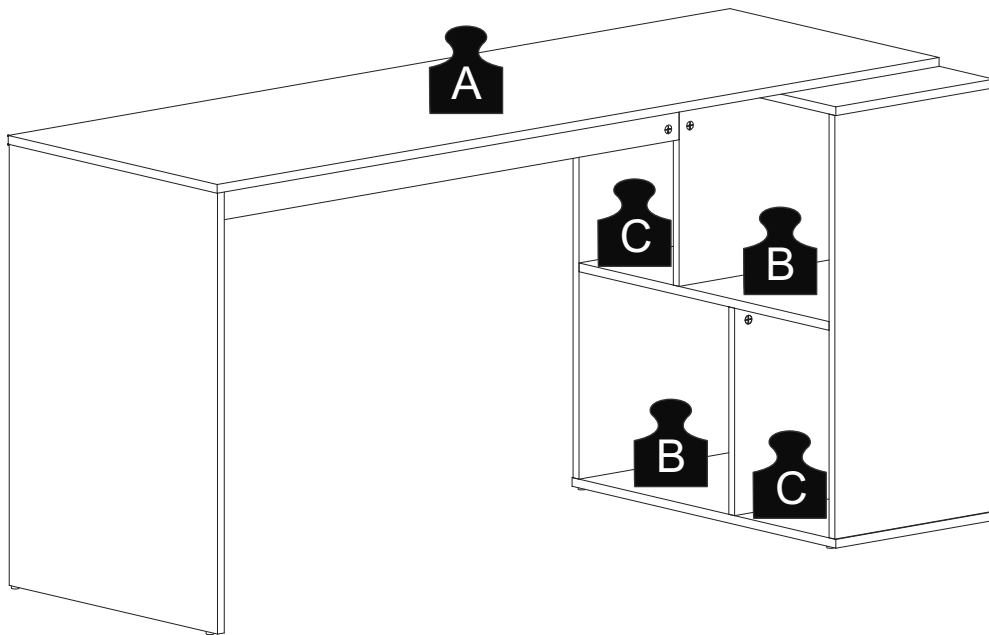

PASSO 1 / STEP 1 / PASO 1

Insira a ferragem EF 000094 nas peças 02, 03, 04, 07 e 08.
Insert hardware EF 000094 into pieces 02, 03, 04, 07 and 08.
Añade el herraje EF 000094 en las piezas 02, 03, 04, 07 y 08.

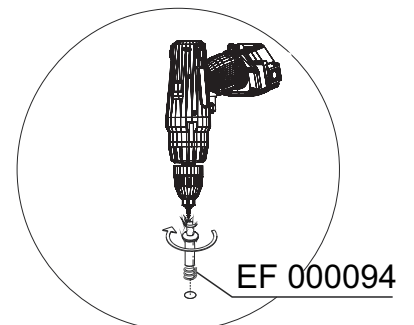
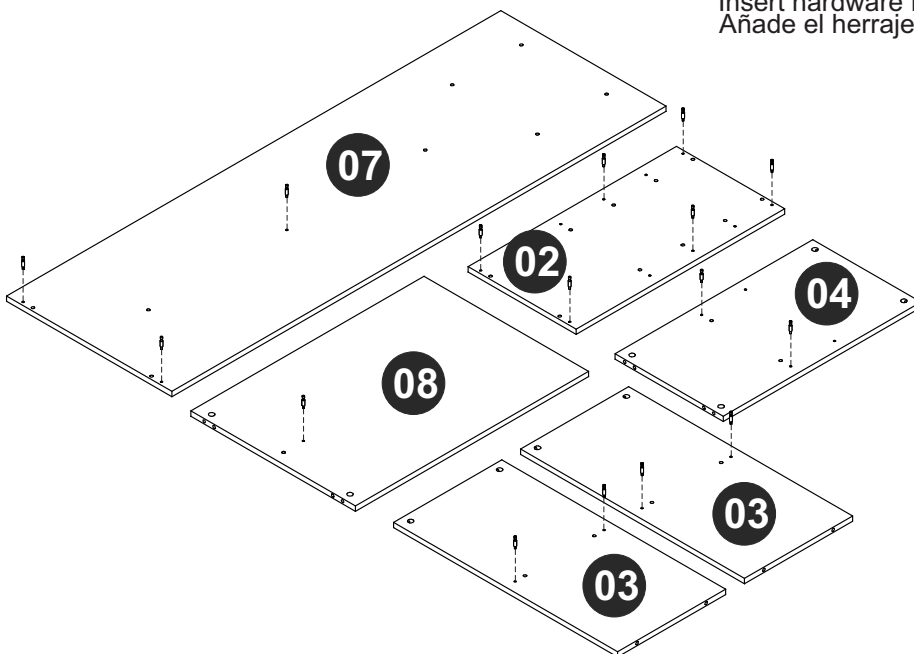

PASSO 2 / STEP 2 / PASO 2

Insira a ferragem EF 000033 nas peças 03, 04, 05, 06, 08 e 09.
Insert hardware EF 000033 into pieces 03, 04, 05, 06, 08 and 09.
Añade el herraje EF 000033 en las piezas 03, 04, 05, 06, 08 y 09.

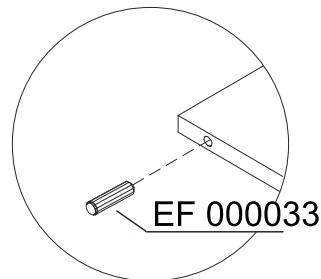
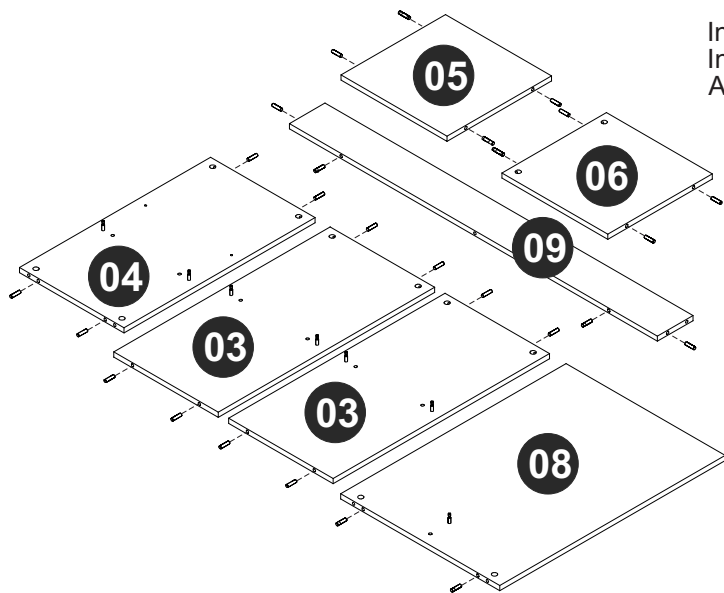

OPÇÃO 1 / OPTION 1 / OPCIÓN 1

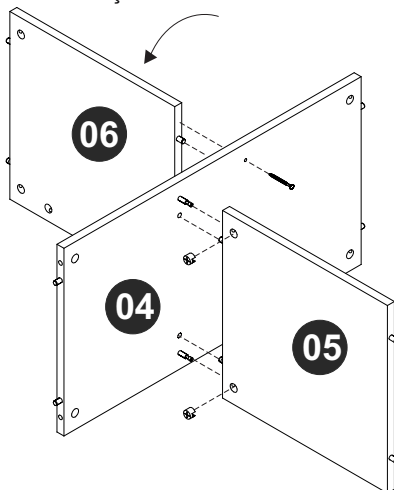

Escolha a posição da peça 06.
Choose the position of piece 06.
Elija la posición de la pieza 06.

OPÇÃO 2 / OPTION 2 / OPCIÓN 2

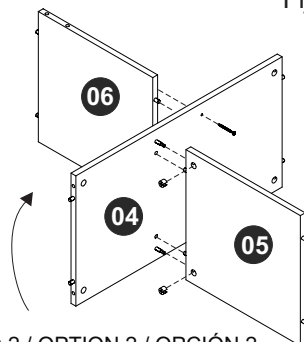

PASSO 3 / STEP 3 / PASO 3

Conecte as peças 05 e 06 na peça 04, insira a ferragem EF 000216 e gire para apertar.

Fixe a peça 06 utilizando a ferragem EF 000132.
Connect pieces 05 and 06 into piece 04, insert hardware EF 000216 and turn to tighten.

Fix piece 06 using hardware EF 000132.

Junte las piezas 05 y 06 en la pieza 04, añade el herraje EF 000216 y gire para apretar.

Fije la pieza 06 utilizando el herraje EF 000132.

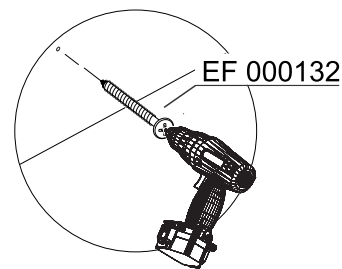
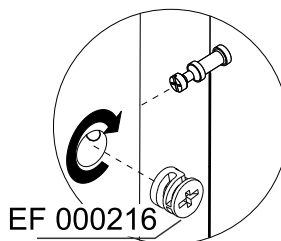

OPÇÃO 1 / OPTION 1 / OPCIÓN 1

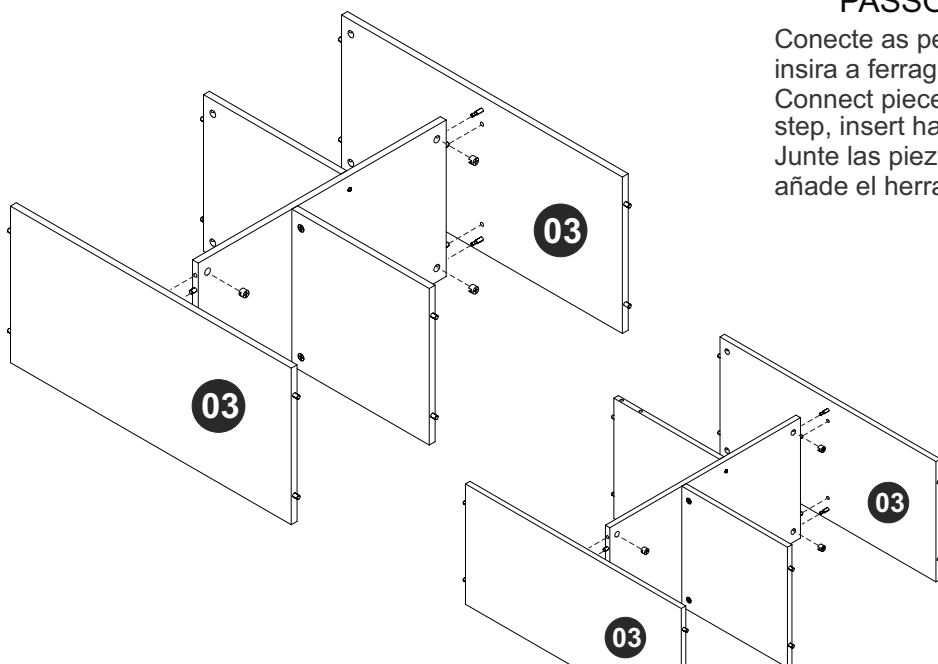

OPÇÃO 2 / OPTION 2 / OPCIÓN 2

PASSO 4 / STEP 4 / PASO 4

Conecte as peças 03 à parte montada no passo anterior, insira a ferragem EF 000216 e gire para apertar.

Connect pieces 03 to the part assembled into the previous step, insert hardware EF 000216 and turn to tighten.

Junte las piezas 03 a la parte armada en el paso anterior, añade el herraje EF 000216 y gire para apretar.

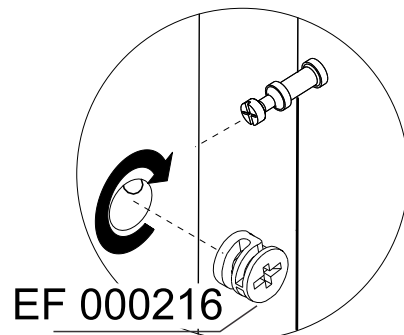

OPÇÃO 1 / OPTION 1 / OPCIÓN 1

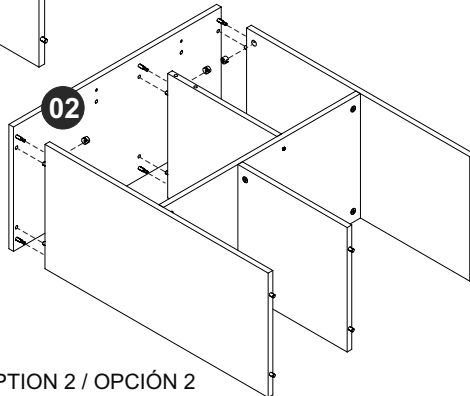
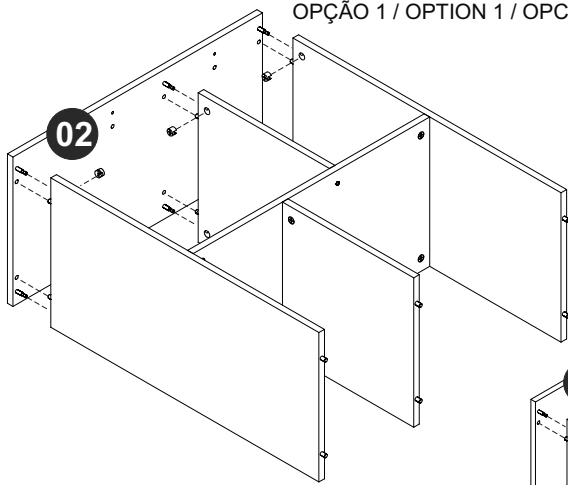

OPÇÃO 2 / OPTION 2 / OPCIÓN 2

PASSO 5 / STEP 5 / PASO 5

Conecte a peça 02 à parte montada no passo anterior, insira a ferragem EF 000216 e gire para apertar.
 Connect piece 02 to the part assembled into the previous step, insert hardware EF 000216 and turn to tighten.
 Junte la pieza 02 a la parte armada en el paso anterior, añade el herraje EF 000216 y gire para apretar.

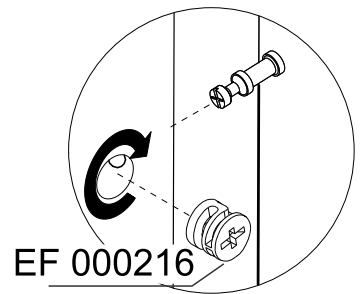

OPÇÃO 1 / OPTION 1 / OPCIÓN 1

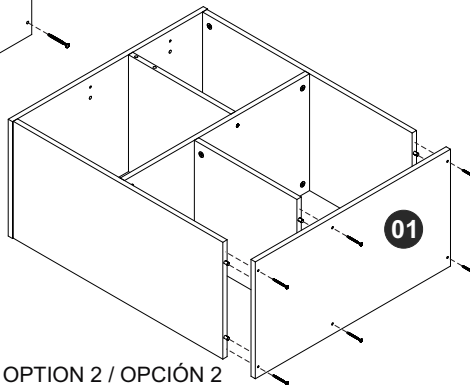
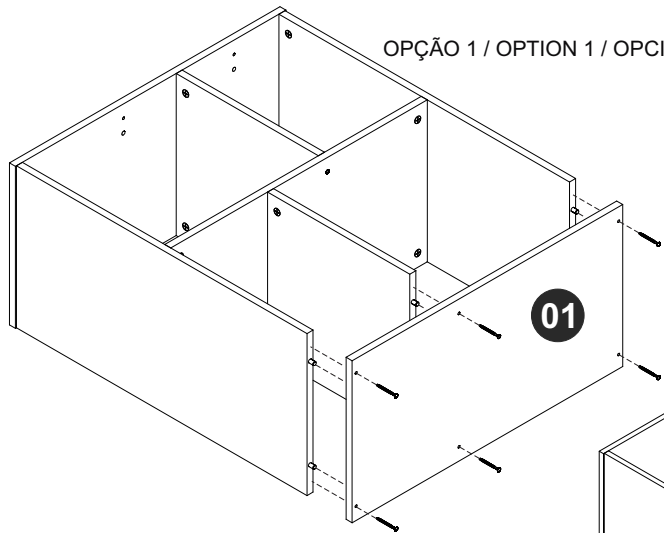

OPÇÃO 2 / OPTION 2 / OPCIÓN 2

PASSO 6 / STEP 6 / PASO 6

Conecte a peça 01 ao móvel montado utilizando a ferragem EF 000132.
 Connect piece 01 at the assembled furniture using hardware EF 000132.
 Junte la pieza 01 al mueble armado utilizando el herraje EF 000132.

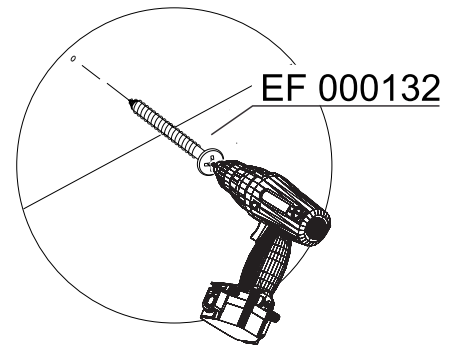

OPÇÃO 1 / OPTION 1 / OPCIÓN 1

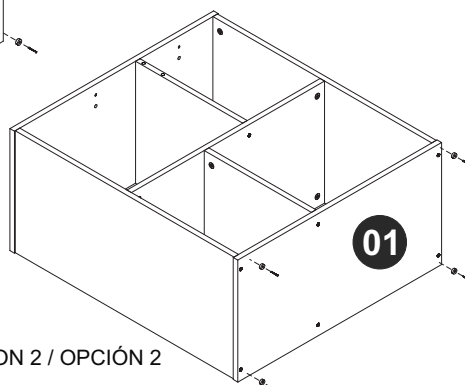
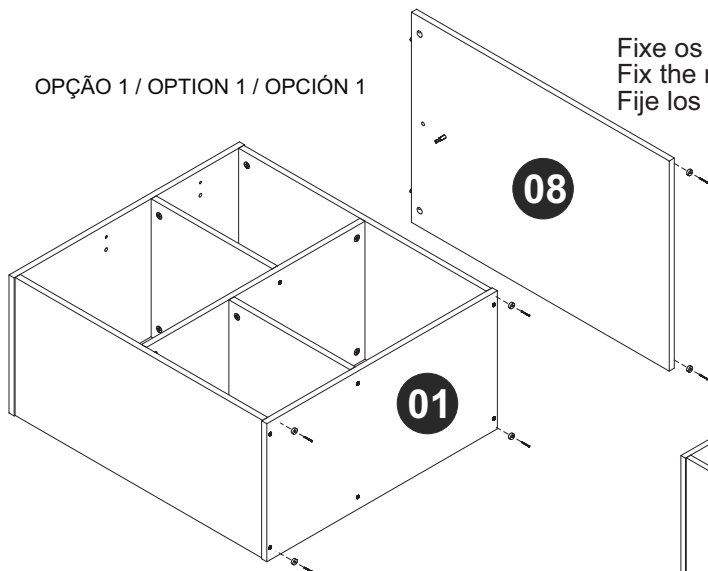

OPÇÃO 2 / OPTION 2 / OPCIÓN 2

PASSO 7 / STEP 7 / PASO 7

Fixe os pés redondos nas peças 01 e 08 utilizando a ferragem EF 000106.
 Fix the round feet at pieces 01 and 08 using hardware EF 000106.
 Fije los pies redondos en las piezas 01 y 08 utilizando el herraje EF 000106.

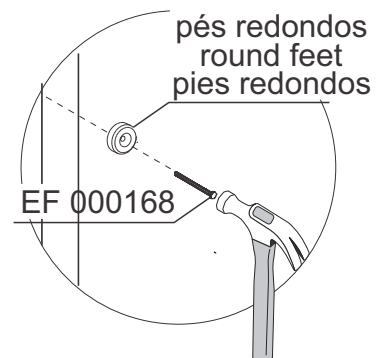

PASSO 8 / STEP 8 / PASO 8

Fixe as peças 10 utilizando a ferragem EF 000168.
Fix the pieces 10 using hardware EF 000168.
Fije las piezas 10 utilizando el herraje EF 000168.

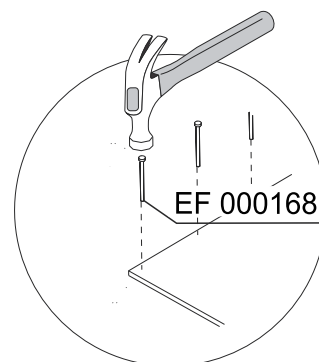
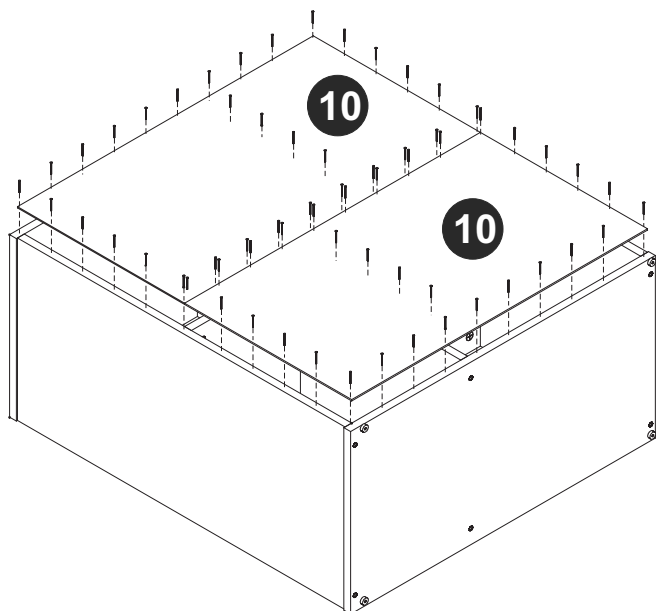

PASSO 9 / STEP 9 / PASO 9

Conecte as peças 08 e 09, insira a ferragem EF 000216 e gire para apertar.
Connect pieces 08 and 09, insert hardware EF 000216 and turn to tighten.
Junte las piezas 08 y 09, añada el herraje EF 000216 y gire para apretar.

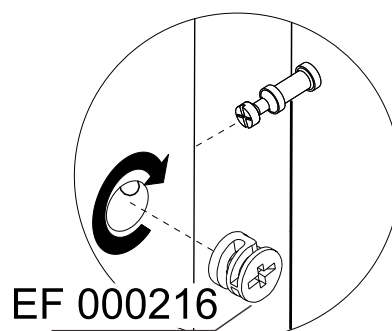
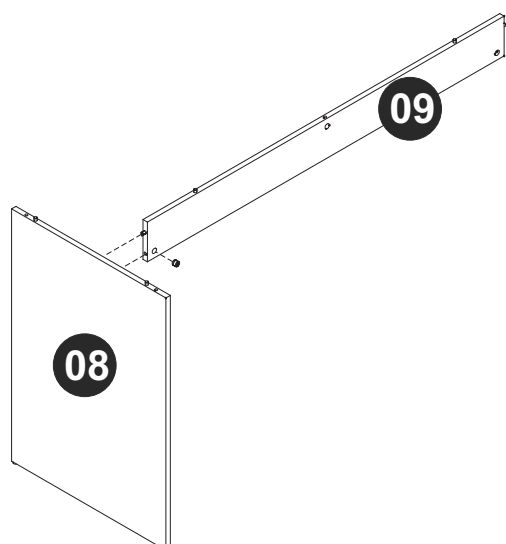

OPÇÃO 1 / OPTION 1 / OPCIÓN 1

PASSO 10 / STEP 10 / PASO 10

Insira as ferragens EF 000751 e EF 000731 na peça 06, conecte a peça 09, insira a ferragem EF 000216 e gire para apertar.
Insert hardware EF 000751 and EF 000731 into piece 06, connect piece 09, insert hardware EF 000216 and turn to tighten.
Añade el herraje EF 000751 y EF 000731 a la pieza 06, junte la pieza 09, añada el herraje EF 000216 y gire para apretar.

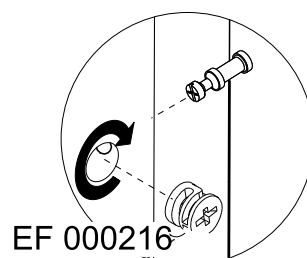
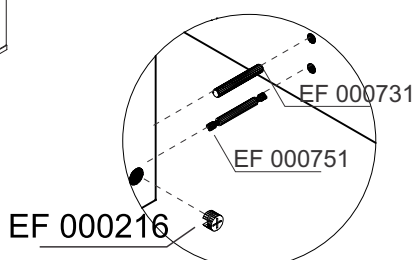
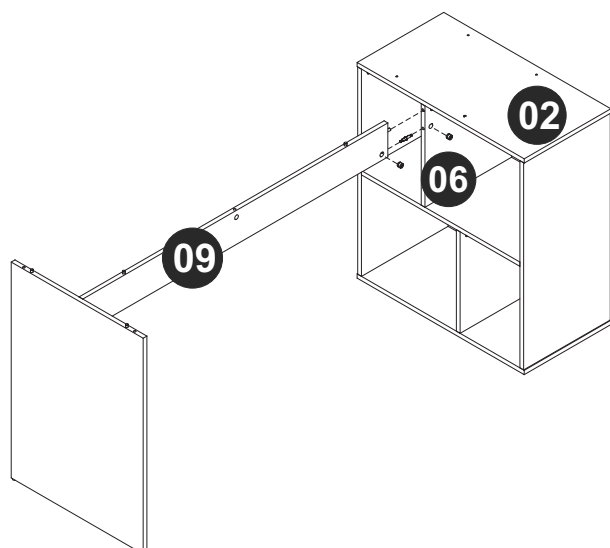

OPÇÃO 2 / OPTION 2 / OPCIÓN 2

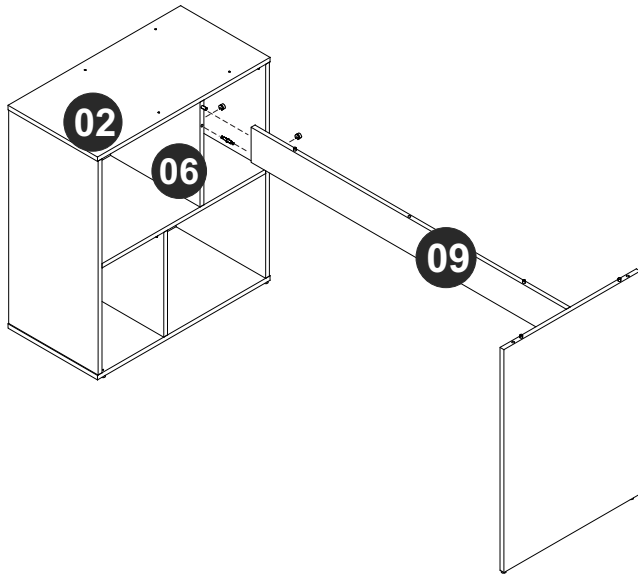

PASSO 11 / STEP 11 / PASO 11

Insira as ferragens EF 000751 e EF 000731 na peça 06, conecte a peça 09, insira a ferragem EF 000216 e gire para apertar.
Insert hardware EF 000751 and EF 000731 into piece 06, connect piece 09, insert hardware EF 000216 and turn to tighten.
Añade el herraje EF 000751 y EF 000731 a la pieza 06, junte la pieza 09, añade el herraje EF 000216 y gire para apretar.

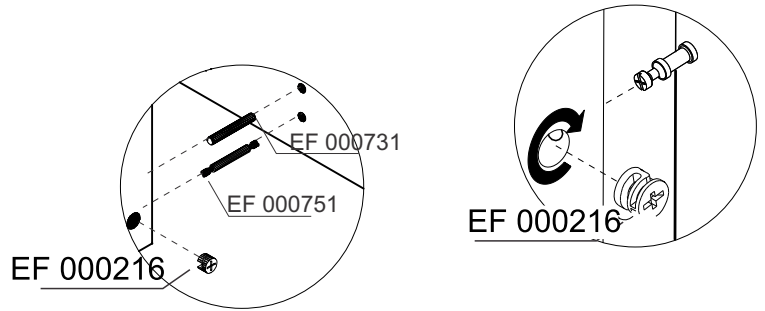

OPÇÃO 1 / OPTION 1 / OPCIÓN 1

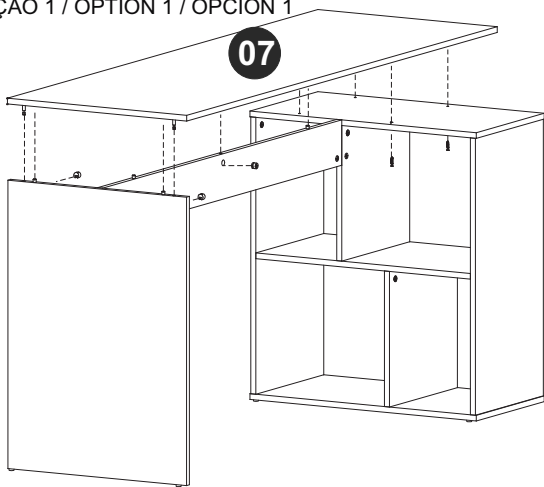

PASSO 12 / STEP 12 / PASO 12

Conecte a peça 07 à parte montada no passo anterior, insira a ferragem EF 000216 e gire para apertar.
Fixe a peça 07 utilizando a ferragem EF 000404.
Connect piece 07 to the part assembled into the previous step, insert hardware EF 000216 and turn to tighten.
Fix piece 07 using hardware EF 000404.
Junte la pieza 07 a la parte armada en el paso anterior, añade el herraje EF 000216 y gire para apretar.
Fije la pieza 07 utilizando el herraje EF 000404.

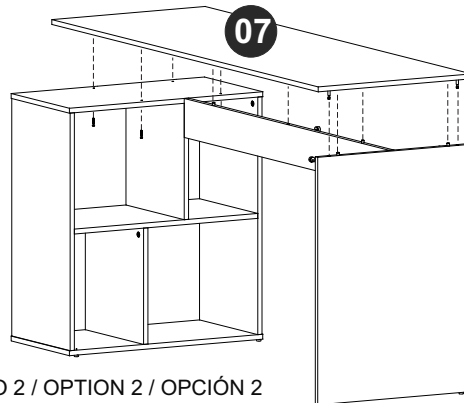

OPÇÃO 2 / OPTION 2 / OPCIÓN 2

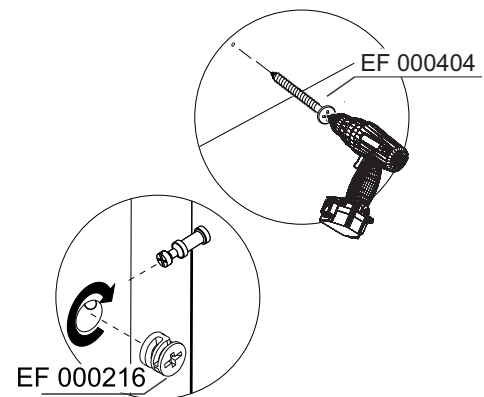

OPÇÃO 1 / OPTION 1 / OPCIÓN 1

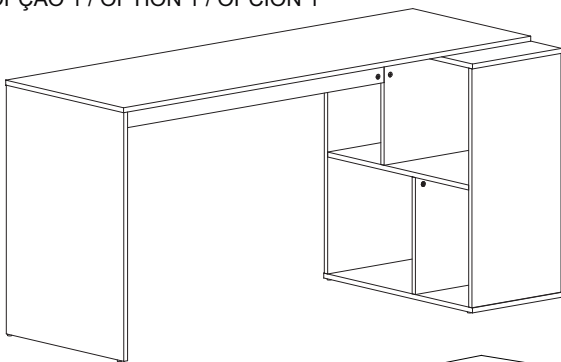

PASSO 13 / STEP 13 / PASO 13

Utilize o tapa furos para cobrir os parafusos aparentes.
Use the sticker to cover the apparent screws.
Utilice los tapa huecos para cubrir los tornillos aparentes.
Utilize o giz para dar o acabamento final ao produto.
Use the chalk to give the final finish on the product.
Utilice la tiza para dar el acabado final al producto.

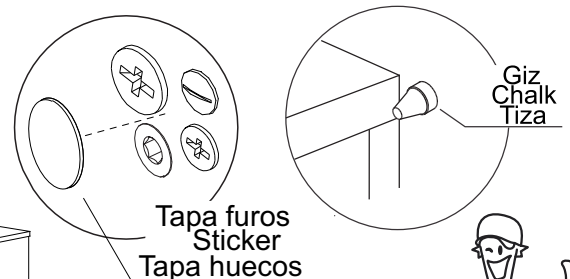

Tapa furos
Sticker
Tapa huecos

Giz
Chalk
Tiza

OPÇÃO 2 / OPTION 2 / OPCIÓN 2

